

## Kombihalter

für Maschinenhersteller

**Mazak**

für Maschinentyp

**NEXUS QTNX + SQT**

■ Reduzierhülsen und Spannzangeneinsätze  
Seite 293-294



Interne Kühlmittelzufuhr

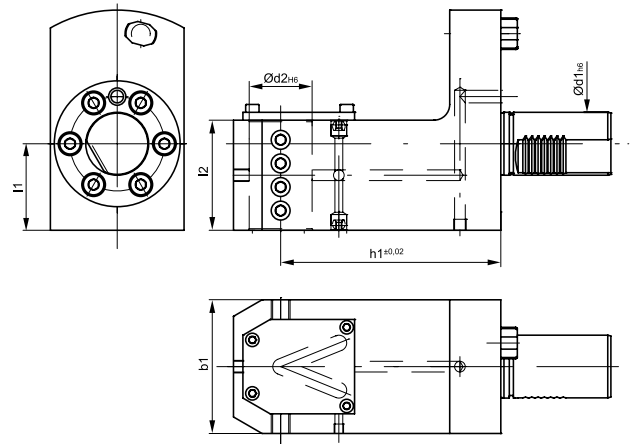

Bestell-Nr.	Größe	Maschine	d1 mm	d2 mm	l1 mm	l2 mm	b1 mm	h1 mm
117971	VDI 40	QTNX 100 + SQT 10	40	25	55	65	76	110
117972	VDI 40	QTNX 100 + SQT 10	40	32	55	65	76	110
117961	VDI 40	QTNX 100 + SQT 10	40	40	55	65	76	110
152680	VDI 40	QTNX 200/250 + SQT 15	40	25	55	70	85	140
152681	VDI 40	QTNX 200/250 + SQT 15	40	32	55	70	85	140
152682	VDI 40	QTNX 200/250 + SQT 15	40	40	55	70	85	140
118018	VDI 50	QTNX 300/350 + SQT 28/30	50	32	63	90	92	175
118008	VDI 50	QTNX 300/350 + SQT 28/30	50	50	63	90	92	175

## Kombihalter, doppelt

für Maschinenhersteller

**Mazak**

für Maschinentyp

**NEXUS QTNX + SQT**



Interne Kühlmittelzufuhr

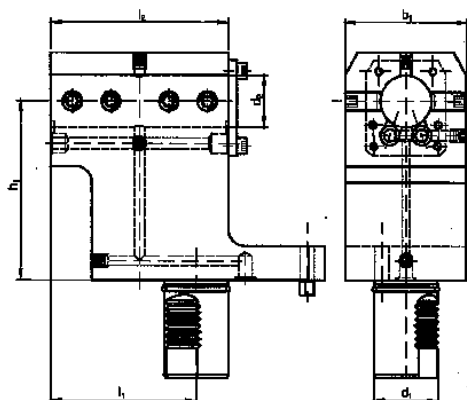

Bestell-Nr.	Größe	Maschine	d1 mm	d2 mm	l1 mm	l2 mm	b1 mm	h1 mm
117976	VDI 40	QTNX 100 + SQT 10	40	32	90	110	76	110
117978	VDI 40	QTNX 200/250 + SQT 15	40	40	90	110	84	140

## Kombi-Außendrehhalter (rechts/links)

für Maschinenhersteller

**Mazak**

für Maschinentyp

**NEXUS QTNX + SQT**



Interne Kühl-  
mittelzufuhr

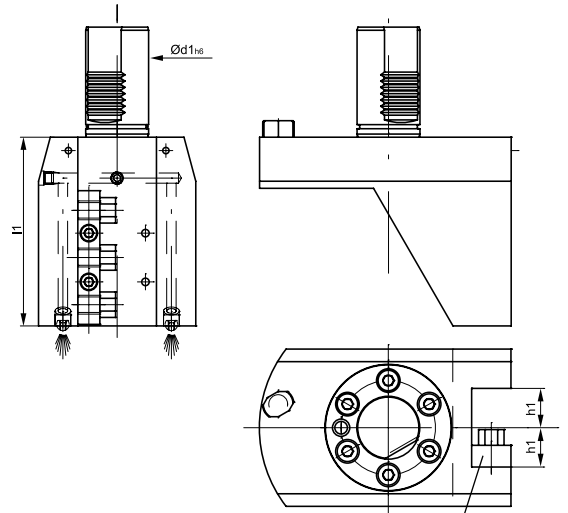

Umsetzbar für Rechts- und Linkslauf

Bestell-Nr.	Größe	Maschine	d1 mm	l1 mm	h1 mm
117986	VDI 40	QTNX 100 + SQT 10	40	100	20
152683	VDI 40	QTNX 200/250 + SQT 15	40	120	25
118022	VDI 50	QTNX 300/350 + SQT 28/30	50	150	25

## Kombi-Duo-Außendrehhalter (rechts/links)

für Maschinenhersteller

**Mazak**

für Maschinentyp

**NEXUS QTNX + SQT**



Interne Kühl-  
mittelzufuhr

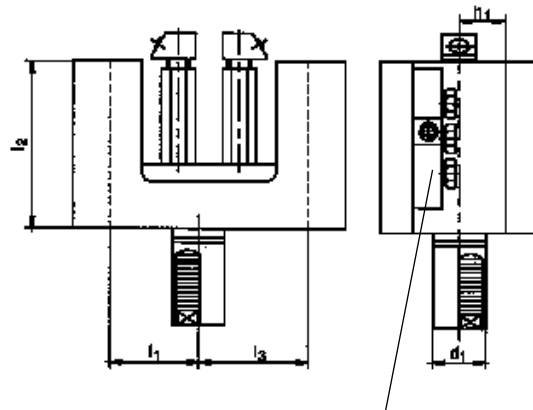

Umsetzbar für Rechts- und Linkslauf

Bestell-Nr.	Größe	Maschine	d1 mm	l1 mm	l2 mm	l3 mm	h1 mm
117988	VDI 40	QTNX 100 + SQT 10	40	45	100	73	20
117996	VDI 40	QTNX 200/250 + SQT 15	40	40	125	70	25
118010	VDI 50	QTNX 300/350 + SQT 28/30	50	46	146	75	25

## Kombi-Plandrehhalter (rechts/links)

für Maschinenhersteller

**Mazak**

für Maschinentyp

**NEXUS QTNX + SQT**



Interne Kühl-  
mittelzufuhr

Umsetzbar für Rechts- und Linkslauf

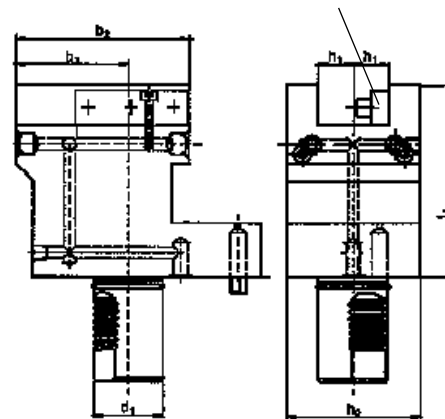

Bestell-Nr.	Größe	Maschine	d1 mm	h2 mm	l1 mm	b1 mm	b2 mm	h1 mm
118000	VDI 40	QTNX 100 + SQT 10	40	76	110	60	110	20
117990	VDI 40	QTNX 200/250 + SQT 15	40	86	143	65	115	25
118012	VDI 50	QTNX 300/350 + SQT 28/30	50	98	163	57	120	25

Ebenfalls in unserem Programm sind statische Werkzeughalter mit Capto-Schnittstelle. Bitte fordern Sie bei Interesse weiterführende Unterlagen an.

Abbildung zeigt einen geraden statischen Werkzeughalter mit Capto C4 Schnittstelle für Mazak MP 6200.

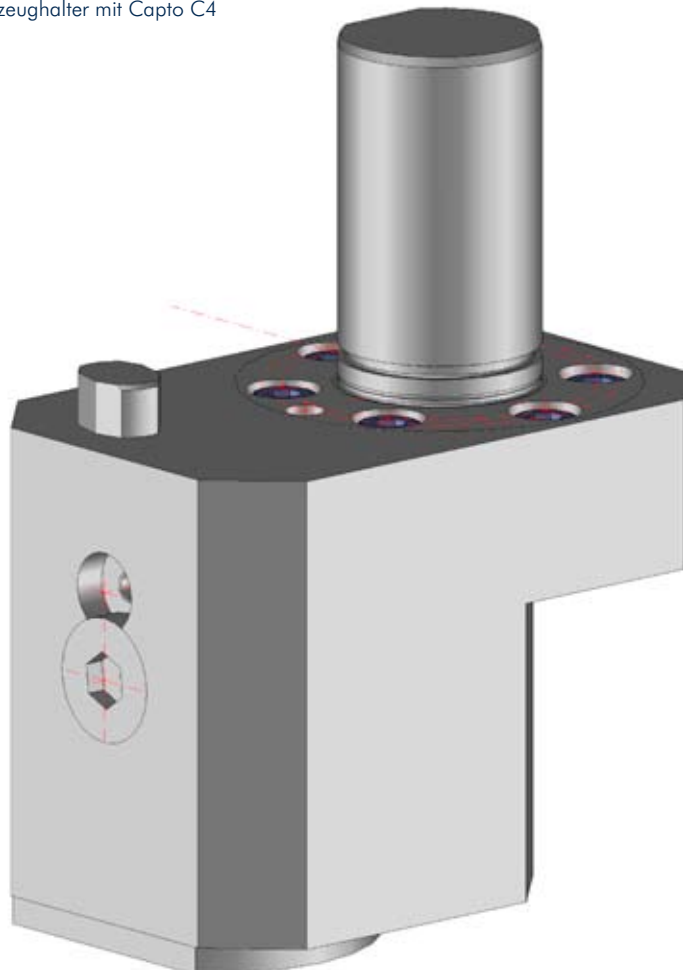

## Kombihalter

für Maschinenhersteller

**Mazak**

für Maschinentyp

**Multiplex MP**

- Reduzierhülsen und Spannzangeneinsätze  
Seite 300



Interne Kühl-  
mittelzufuhr

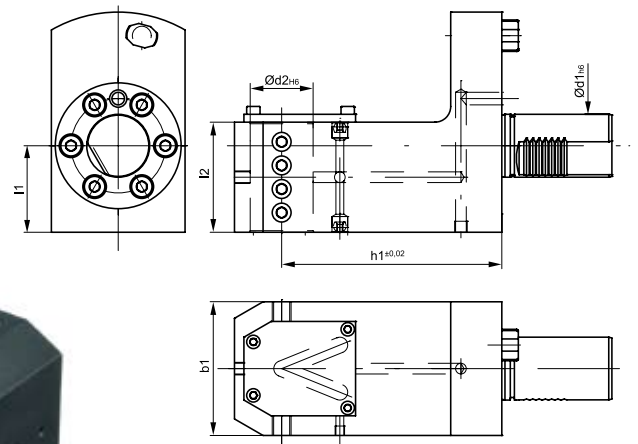

Bestell-Nr.	Größe	Maschine	d1 mm	d2 mm	l1 mm	l2 mm	b1 mm	h1 mm
117979	VDI 40	MP 610	40	25	10	65	76	130
117981	VDI 40	MP 610	40	32	10	65	76	130
117982	VDI 40	MP 610	40	40	10	65	76	130
117983	VDI 40	MP 620	40	25	10	70	76	150
117964	VDI 40	MP 620	40	32	10	70	76	150
117984	VDI 40	MP 620	40	40	10	70	76	150
117985	VDI 40	MP 620	40	50	10	70	76	150

## Kombi-Außendrehhalter

für Maschinenhersteller

**Mazak**

für Maschinentyp

**Multiplex MP**



Interne Kühl-  
mittelzufuhr

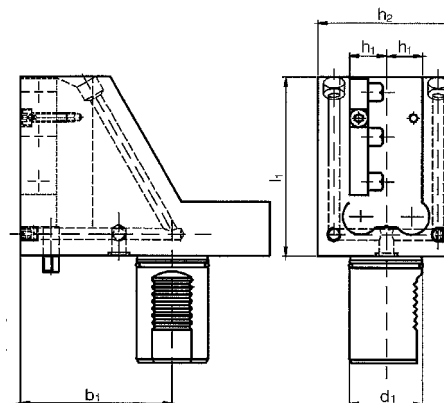

Bestell-Nr.	Größe	Maschine	d1 mm	l1 mm	h2 mm	b1 mm	h1 mm
117997	VDI 40	MP 610	40	100	76	85	20
117998	VDI 40	MP 620	40	120	50	83	25

# Kombi-Plandrehhalter

für Maschinenhersteller

**Mazak**

für Maschinentyp

**Multiplex MP**



Interne Kühlmittelzufuhr

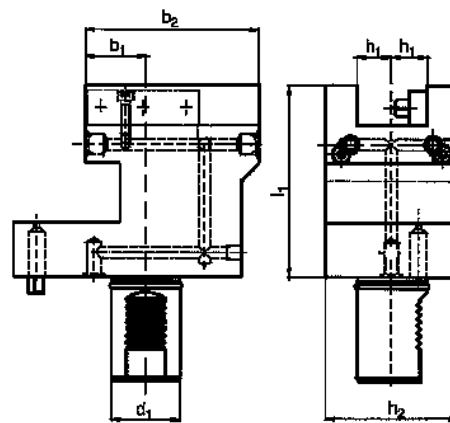

Bestell-Nr.	Größe	Maschine	d1 mm	b2 mm	l1 mm	h2 mm	b1 mm	h1 mm
117992	VDI 40	MP 610	40	100	110	76	35	20
117993	VDI 40	MP 620	40	115	143	80	35	25

## Zubehör für Kombihalter

### Reduzierhülse



Abb. 1



Abb. 2

Bestell-Nr.	Abb.	d1 mm	d2 mm	d3 mm	d4 mm	l1 mm	l2 mm
104527	1	25		6	29	50	4
104444	1	25		8	29	50	4
104445	1	25		10	29	50	4
104494	1	25		12	29	50	4
104537	2	25	16		29	50	4
104469	2	25	20		29	50	4
104528	1	32		6	40	58	5
104519	1	32		8	40	58	5
104454	1	32		10	40	58	5
104487	1	32		12	40	58	5
104548	2	32	16		40	58	5
104489	2	32	20		40	58	5
104522	2	32	25		40	58	5

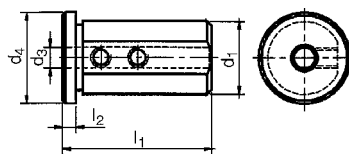
Bestell-Nr.	Abb.	d1 mm	d2 mm	d3 mm	d4 mm	l1 mm	l2 mm
104507	1	40		8	44	58	5
104549	1	40		10	44	58	5
104531	1	40		12	44	58	5
104514	2	40	16		44	58	5
104555	2	40	20		44	58	5
104551	2	40	25		44	58	5
104609	2	40	32		44	58	5
104558	1	50		12	54	75	5
104525	2	50	16		54	75	5
104586	2	50	20		54	75	5
104587	2	50	25		54	75	5
104588	2	50	32		54	75	5
104559	2	50	40		54	75	5

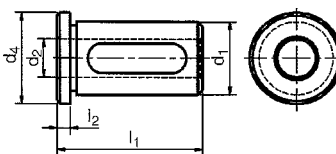

## Zubehör für Kombihalter

### Spannzangeneinsatz

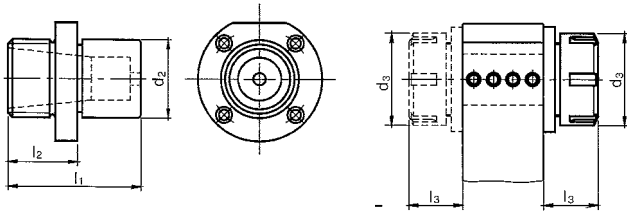

Bestell-Nr.	d2 mm	Größe	Bereich	d3 mm	l1 mm	l2 mm	l3 mm
135232	32	E 430	2-16	42	49	25	37
135239	32	E 470	3-20	50	52	28	41
135234	40	E 430	2-16	42	49	25	37
135238	40	E 470	3-20	50	52	28	41
135233	50	E 472	4-26	63	52	28	42

### Spannzangensatz DIN 6499, Klasse 2



Bestell-Nr.	Stück	Größe	Bereich
152712	10	ER 16	1-10
152713	15	ER 25	2-16
152715	18	ER 32	3-20
152716	23	ER 40	4-26

### Bohrer-Einsatzhülse

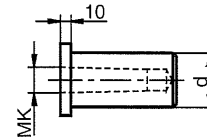

Bestell-Nr.	d mm	MK
105152	25	1
105134	25	2
105176	32	1
105191	32	2
105192	32	3
105086	40	1
105125	40	2
105103	40	3
105120	40	4
105068	50	2
105049	50	3
105087	50	4

### Verschlussstopfen aus Stahl für MAZAK CNC-Drehmaschinen

Bestell-Nr.	Größe
118017	VDI 40
118049	VDI 50