

**Data**

Machine type Series		Turret Stations
<b>NL</b>	<b>1500</b>	12
<b>NL</b>	<b>2000</b>	12
<b>NL</b>	<b>2500</b>	12
<b>NL</b>	<b>3000</b>	12

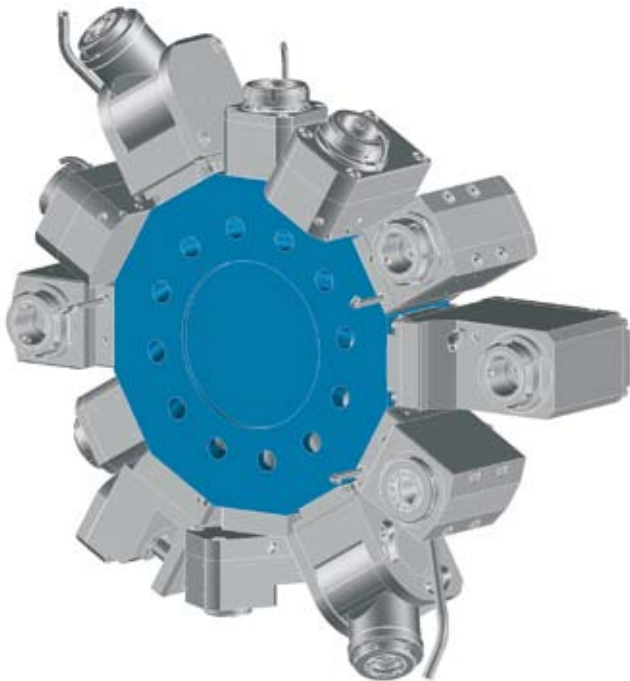

**Star-type Turret „BMT“**



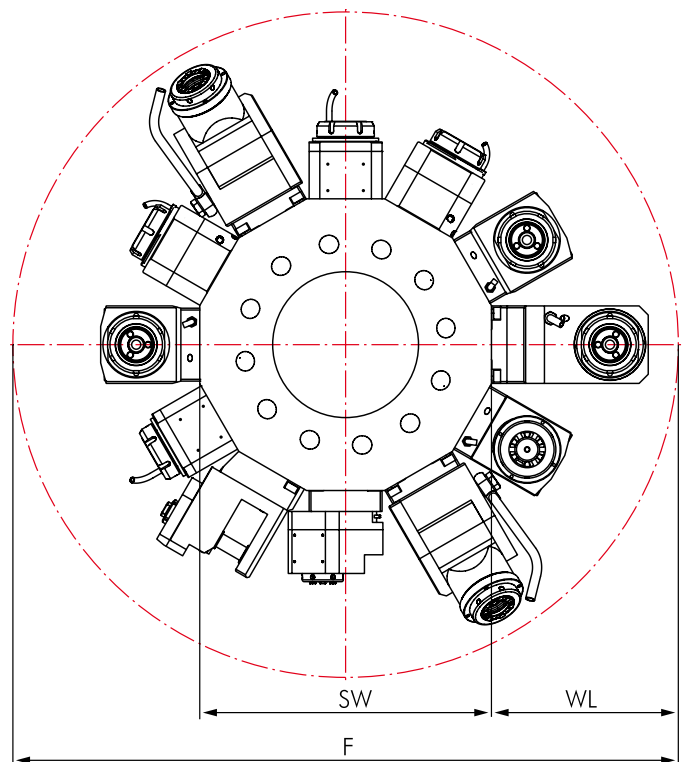

**Interference Circles**



Machine type Series	F	SW	WL
<b>NL 1500/2000/2500</b>	732	420	156
<b>NL 3000</b>	781	470	155,5

## Driven Toolholders

	Page		Page		
<b>Straight Unit</b>		246	<b>Angle Unit, 2-Axis</b>		248
<b>Angle Unit</b>		247			

## Options and Accessories

<b>mi Toolholders</b>		mi System Description Toolholders Accessories	275 278-283 283-284
<b>Accessories</b>		Collets DIN 6499 Threading Collets Wrenches Clamping Nuts Sleeves and Bushings	309 309 309 309 310



## Straight Unit

for Manufacturer	
<b>MORI SEIKI</b> THE MACHINE TOOL COMPANY	
for Machine type	
<b>NL 1500 / 2000 / 2500 / 3000</b>	
Dimensions	
Turret type	Star-type Turret
Shank	BMT Ø 60 mm
Drive	Tang
SW	7.9 mm

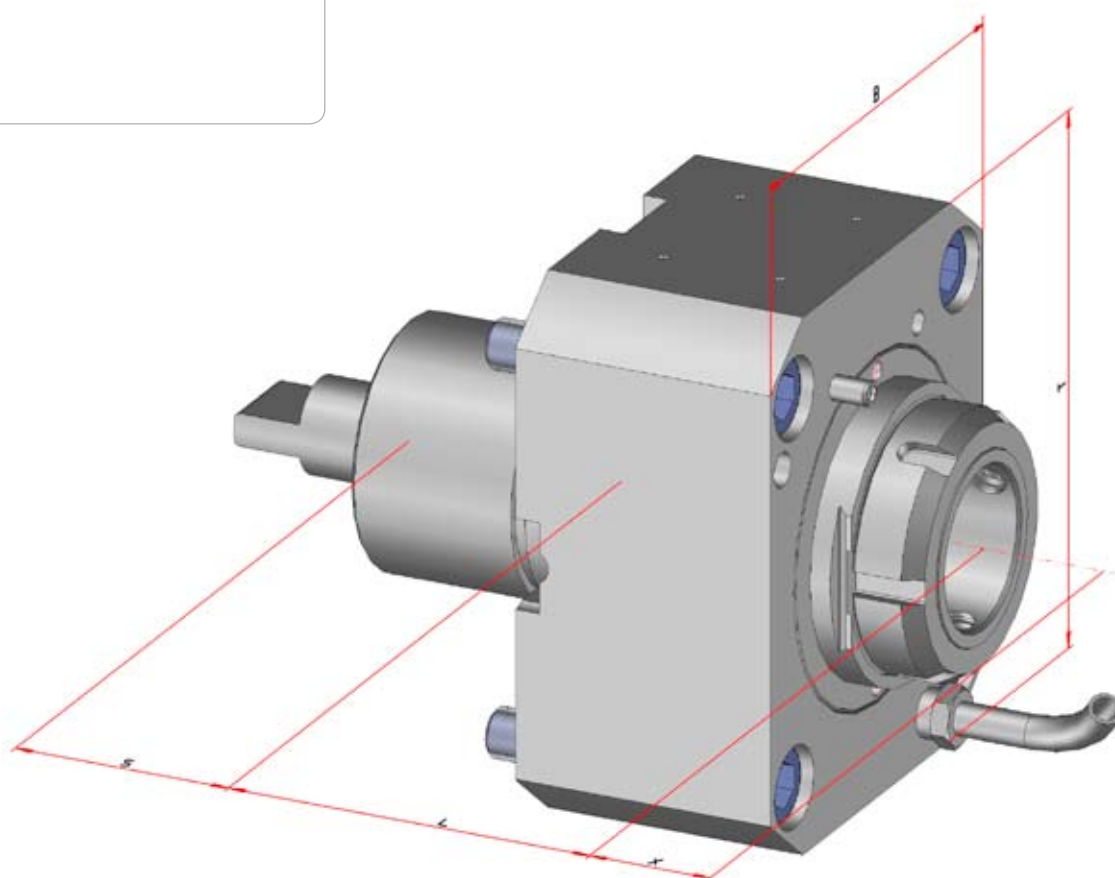

Order No.	Tool holder	Clamping range mm	Torque max.	n1/n2 (max.) (r.p.m.)	Gear Ratio	Coolant	X mm	L mm	B mm	B1 mm	S mm	T mm	MORI SEIKI Ref. #
100471	ER 40	2,5-30	70 Nm	6.500 / 6.500	i = 1:1	external	-	115	108	54	53	130	T32213
124262	ER 40	2,5-30	70 Nm	6.500 / 6.500	i = 1:1	internal	-	115	108	54	53	130	-
124263	mi 50		70 Nm	6.500 / 6.500	i = 1:1	internal	-	90	108	54	53	130	-

# Angle Unit

for Manufacturer

**MORI SEIKI**  
THE MACHINE TOOL COMPANY

for Machine type

**NL 1500 / 2000 / 2500 / 3000**

Dimensions

Turret type	Star-type Turret
Shank	BMT Ø 60 mm
Drive	Tang
SW	7.9 mm

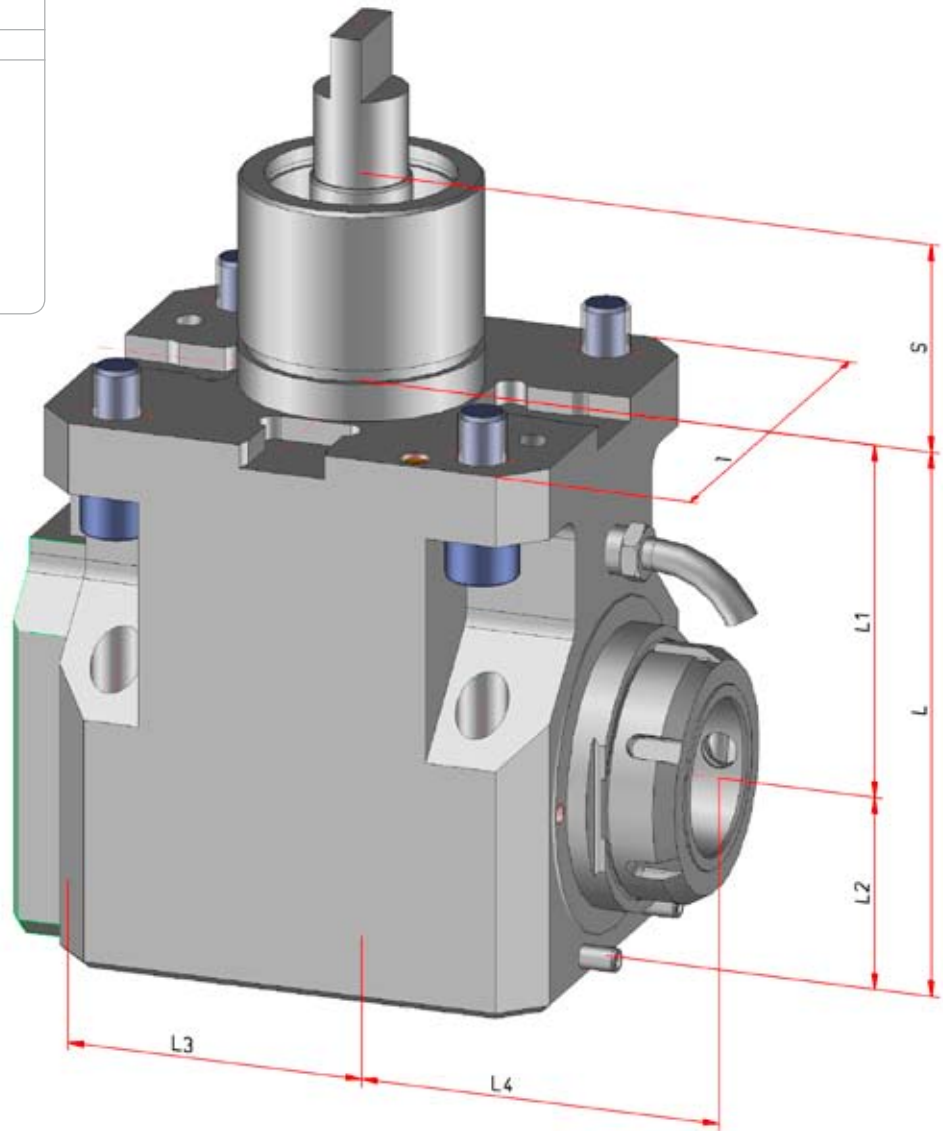

Order No.	Tool holder	Clamping range mm	Torque max.	n1/n2 (max.) (r.p.m.)	Gear Ratio	Coolant	L mm	L1 mm	L2 mm	L3 mm	L4 mm	S mm	T mm	MORI SEIKI Ref. #
101219	ER 40	2,5-30	70 Nm	6.500 / 6.500	i = 1:1	external	139	90	49	75,5	117	53	130	T32214
124882	ER 40	2,5-30	70 Nm	6.500 / 6.500	i = 1:1	internal	139	90	49	75,5	117	53	130	-
124883	mi 50		70 Nm	6.500 / 6.500	i = 1:1	internal	139	90	49	75,5	92	53	130	-

## Angle Unit, 2-Axis

for Manufacturer	
<b>MORI SEIKI</b> THE MACHINE TOOL COMPANY	
for Machine type	
<b>NL 1500 / 2000 / 2500 / 3000</b>	
Dimensions	
Turret type	Star-type Turret
Shank	BMT Ø 60 mm
Drive	Tang
SW	7.9 mm

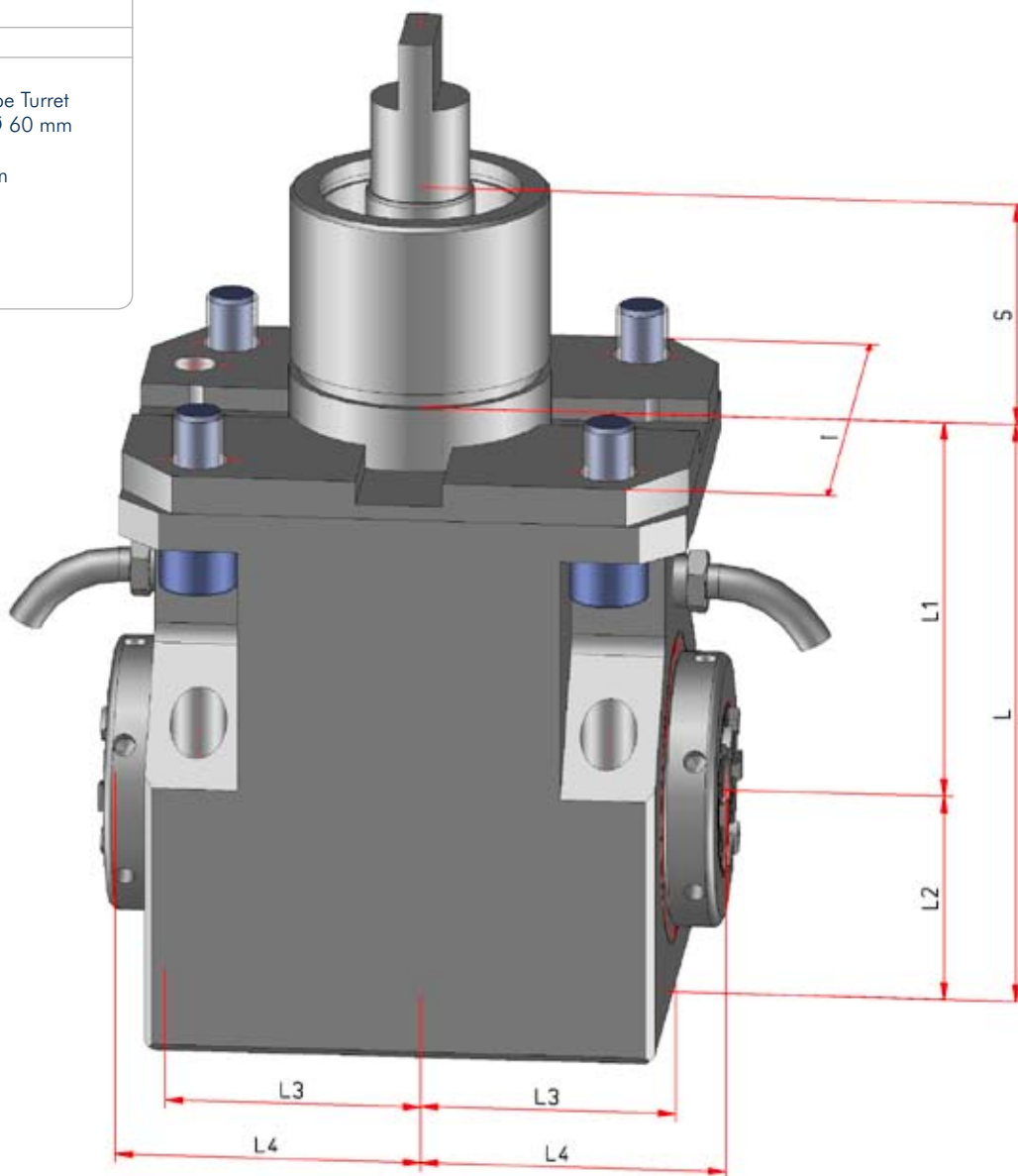

Order No.	Tool holder	Clamping range mm	Torque max.	n1/n2 (max.) (r.p.m.)	Gear Ratio	Coolant	L mm	L1 mm	L2 mm	L3 mm	L4 mm	S mm	T mm	MORI SEIKI Ref. #
101218	2 x ER 32	1,0-20	70 Nm	6.500 / 6.500	i = 1:1	external	139	90	49	70	70	53	130	T32216