

Data

Machine type Series		Turret Stations
ABX	51 TH / SY	12
ABX	64 TH / SY	12

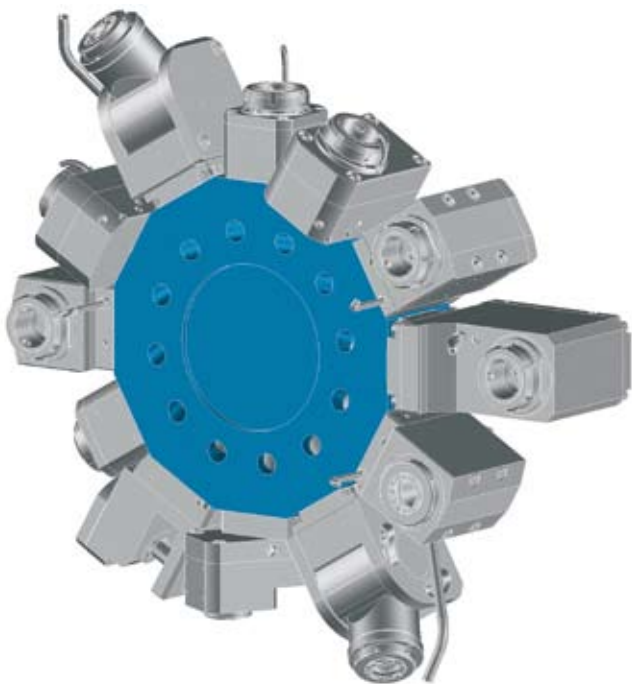

Star-type Turret „BMT“



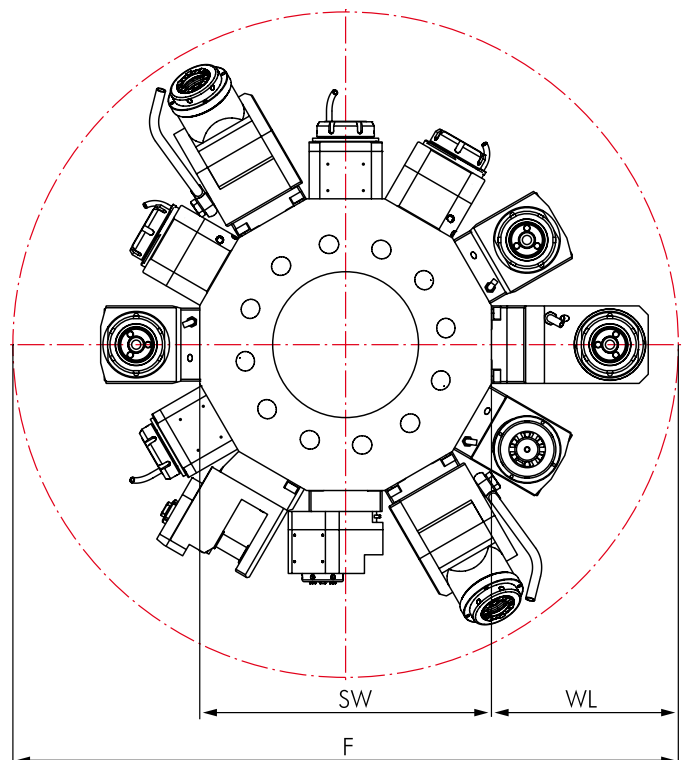

Interference Circles



Machine type Series	F	SW	WL
ABX 51/64	530	320	105

Driven Toolholders

	Page		Page
Straight Unit	256		
		Angle Unit	257
			

Options and Accessories

Accessories		
		
	Collets DIN 6499	309
	Threading Collets	309
	Wrenches	309
	Clamping Nuts	309
	Sleeves and Bushings	310



Straight Unit

for Manufacturer	
	
for Machine type	
ABX 51 TH ABX 64 TH	
Dimensions	
Turret type	Star-type Turret
Shank	BMT Ø 45 mm
Drive	Tang
SW	6 mm

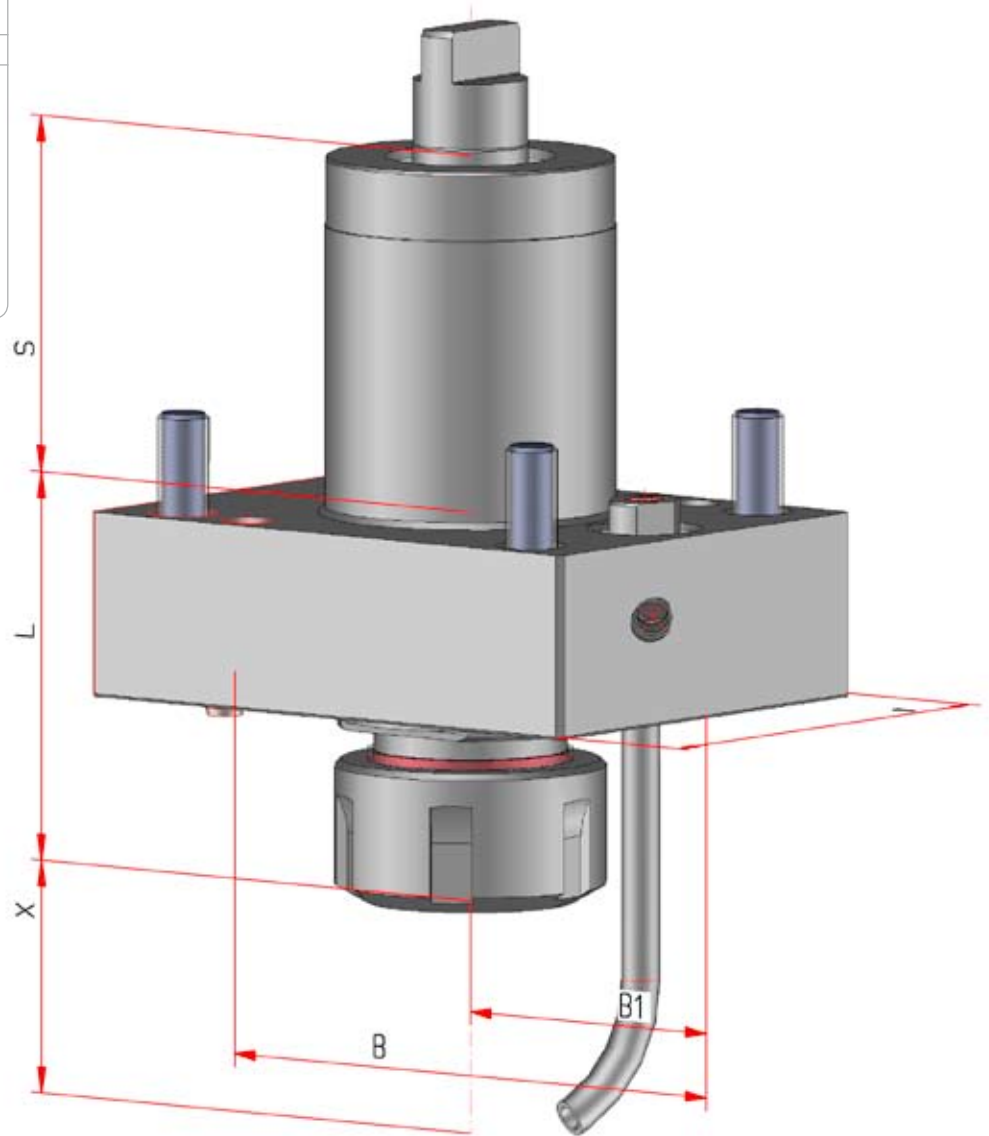

Order No.	Tool holder	Clamping range mm	Torque max.	n1/n2 (max.) (r.p.m.)	Gear Ratio	Coolant	X mm	L mm	B mm	B1 mm	S mm	T mm
123862	ER 25	0,5-16	25 Nm	6.000 / 6.000	i = 1:1	external	44	61	92	46	55	72

Angle Unit

for Manufacturer	
	
for Machine type	
ABX 51 TH ABX 64 TH	
Dimensions	
Turret type	Star-type Turret
Shank	BMT Ø 45 mm
Drive	Tang
SW	6 mm

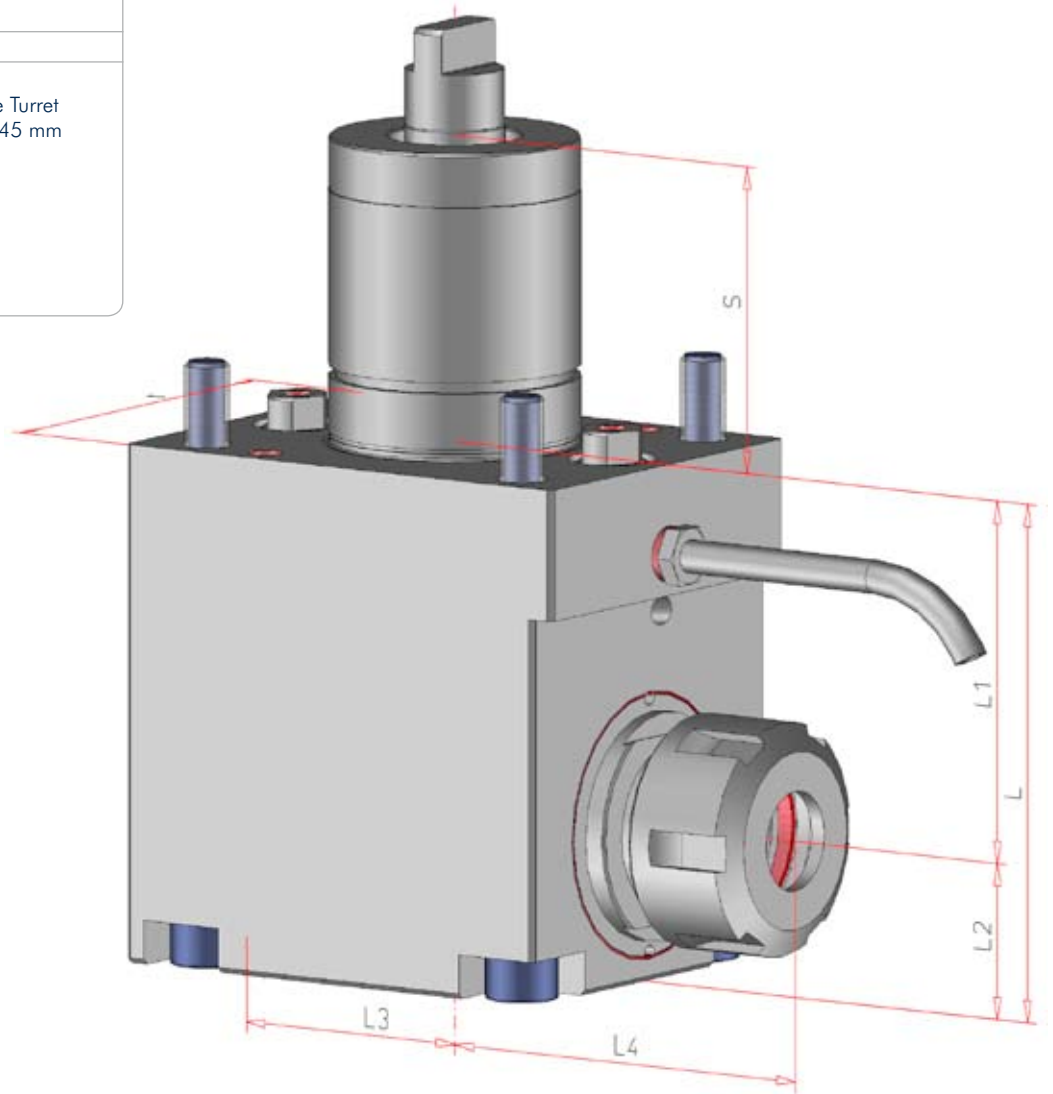

Order No.	Tool holder	Clamping range mm	Torque max.	n1/n2 (max.) (r.p.m.)	Gear Ratio	Coolant	L mm	L1 mm	L2 mm	L3 mm	L4 mm	S mm	T mm
124578	ER 25	0,5-16	25 Nm	6.000 / 6.000	i = 1:1	external	93	65	28	46	74	55	72